

34960

0

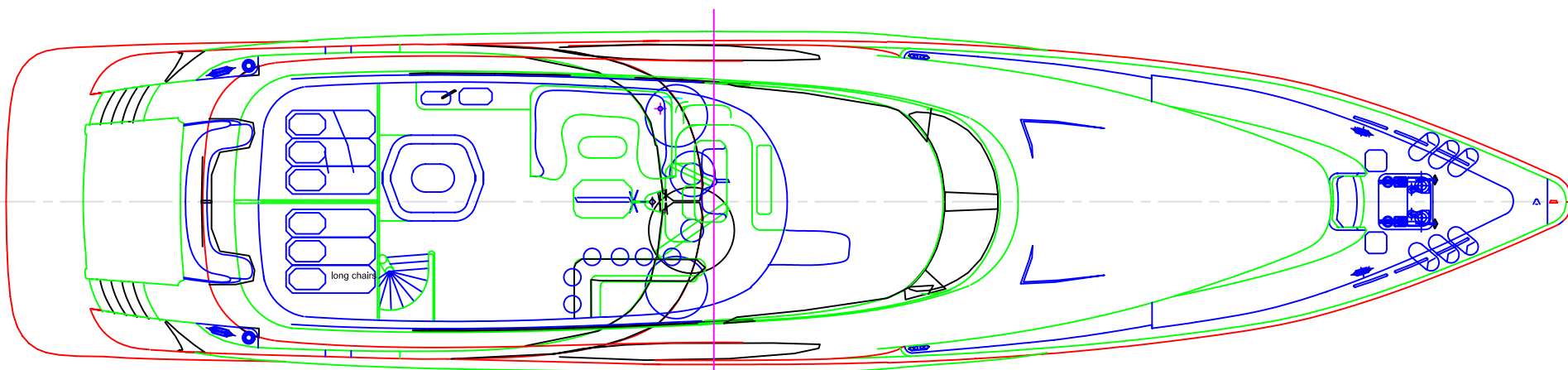

Length o.a. Loa = 36,51 m  
 Length hull Lh = 35,00  
 Length w.l. Lwl = 30,2 m  
 Beam B = 7,54 m  
 DEPTH (amidships), H 3,60 m  
 DRAFT (half/full), T 1,41 m/ 1,50 m  
 FIXED POINT, Hfix (from keel) 9,20 m  
 NAVIGATIONAL DRAFT, Tnav 2,0 m  
 DISPLACEMENT (half/full), D 140 t/ 150 t  
 ENGINES 2xCAT 3516B  
 POWER 2x1939kW/1835rpm  
 SPEED, v 23,5 kn  
 PASSENGERS (24)  
 CLASS. HSC-A OC 4

PRINCIPAL DIMENSIONS

3,60 m  
 1,41 m/ 1,50 m  
 9,20 m  
 2,0 m  
 140 t/ 150 t  
 2xCAT 3516B  
 2x1939kW/1835rpm  
 23,5 kn  
 (24)  
 -

116' FAST MOTORYACHT		
EXTERIOR VIEWS		
Drawn: COR T.D.S.	Date: 23.02.96	Scale: 1:50
Checked: Mulder	Drw.no.: P765-0010	
27.10.97	Yardno.:	
06.9.96	169 Copyright by MULDER DESIGN 165	

HIGH SPEED MOTOR YACHT

SLOVAK SHIPPING & PORTS, JSC., PRIBINOVA 24, 81524 BRATISLAVA, SK			
COOPERATION WITH DANUBE MARINE CONSULTING, spol. s r.o., ADAMIHO 26, 84105 BRATISLAVA, SK			
SLOVAK UNIVERSITY OF TECHNOLOGY, NAM. SLOBODY 17, 81231 BRATISLAVA, SK			
peter.patek@stuba.sk			
Zul. Abw.	Obert	Maßstab: 1:50	Seiten
Datum: 23.02.96		Projekt: oder Gekenn-Nr. im Golden Eye 100' BEIT 1, lady 2'	
Bearb. 20.07.04	PA.TEK	EXTERIOR VIEWS	
06.9.96		02/04-0021	
.UseLy_enn.dwg		A1	

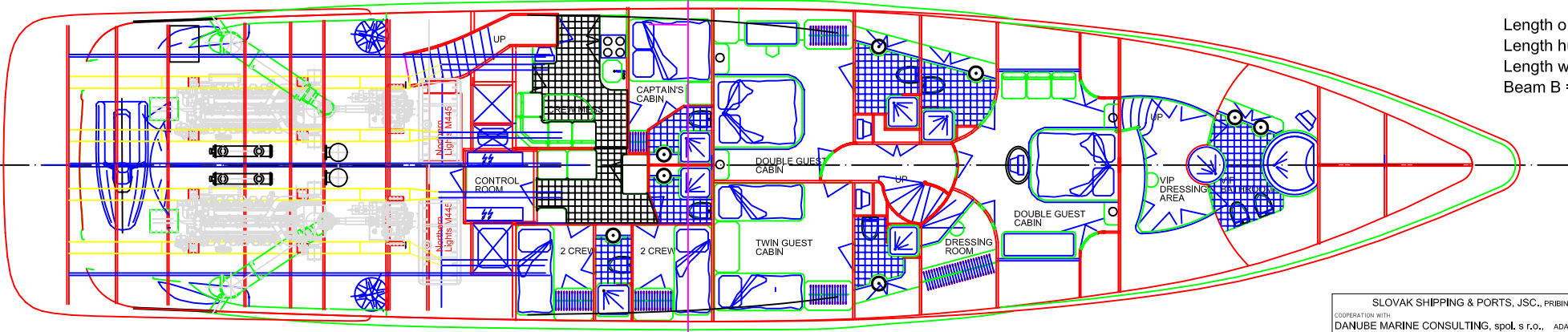
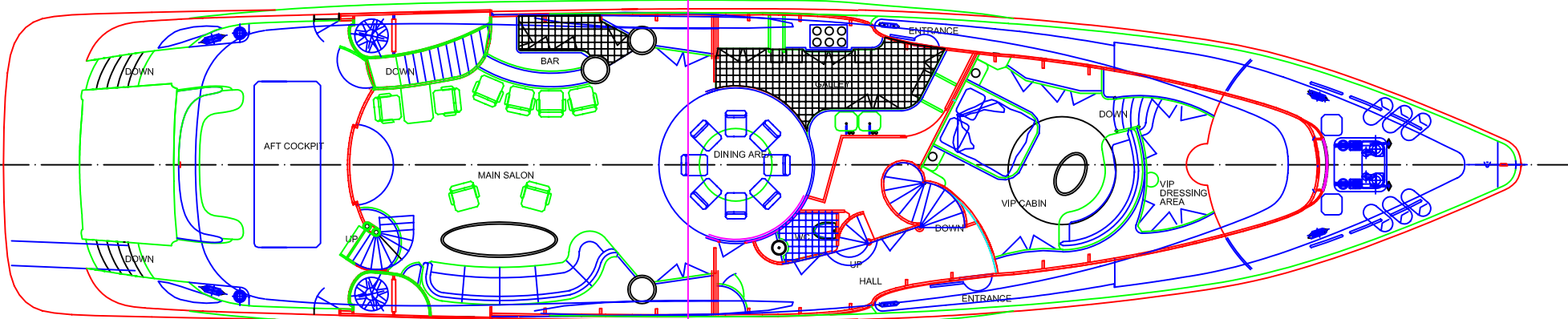
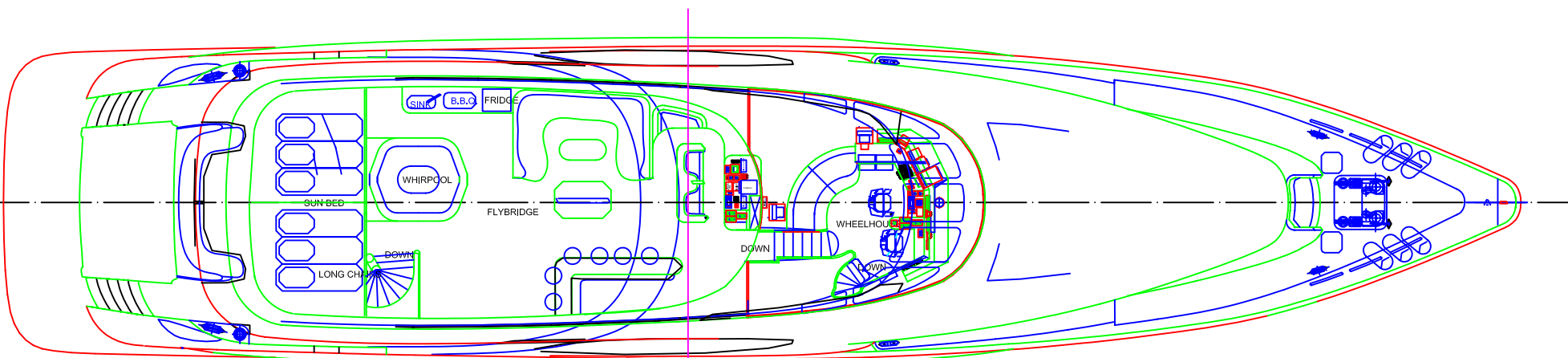

**PRINCIPAL DIMENSIONS**  
 Length o.a. Loa = 36,51 m  
 Length hull Lh = 35,00  
 Length w.l. Lwl = 30,2 m  
 Beam B = 7,54 m

116' FAST MOTORYACHT		
INTERIOR LAYOUT		
INTERIOR DESIGNER: EVAN K MARSHALL		
Drawn: T.D.S.	Date: 23.10.97	Scale: 1:50
Checked: Mulder	Yardno: P765-0020	
Description:	Date:	169 Copyright by MULDER DESIGN 165

SLOVAK SHIPPING & PORTS, JSC., PRIBINOVA 24, 81524 BRATISLAVA, SK			
COOPERATION WITH DANUBE MARINE CONSULTING, spol. s r.o., ADAMIHO 26, 84105 BRATISLAVA, SK			
SLOVAK UNIVERSITY OF TECHNOLOGY, NAM. SLOBODY 17, 81231 BRATISLAVA, SK			
peter.patek@stuba.sk			
Zul. Adv.	Obert	Matlab. 150	Severit
Datum	Verz.	Projekt: eden Golems-10	Projekt: eden Golems-10
Bezh. 20.07.04	PATER	na Golden Eye 102 BERT "Lady Z"	
Sepr.			
INTERIOR LAYOUT			
02/04-0020			A1
UseEn: int.dwg	Scale: 1:50	Scale: 1:50	Scale: 1:50